

PVBM – Transmission Module

Meter-In Meter-Out – Open Circuit Transmission

The Meter-in Meter-out module is designed primarily for use with transmission hydraulic motors in e.g. manlifts or demanding winch applications. Meter-In in term relates to the flow into the system and Meter-Out relates to the flow out of the system.

With the Meter-in Meter-out module both flows in and out of the transmission motors are controlled at the same time.

The Meter-in Meter-out module will ensure a stable, well controlled movement of application when motor pushing (i.e. upwards hill) or motor being pulled (i.e. downward hill) or horizontal movement.

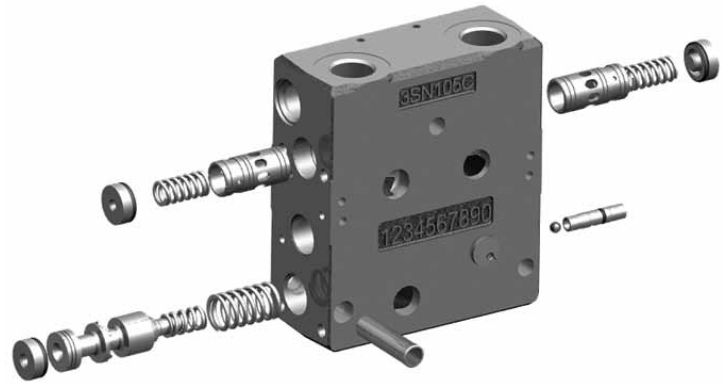

PVBM exploded view

Features

- Integrated shock/anti cavitation valve (A- and B- port)
- T0 connection
- BSP/UNF
- Meter-In compensator
- Meter-Out compensator on A- and B-port
- Increased control of negative loads

Available spools

- Standard PVBS with check valves
- A/B Closed in neutral
- Standard or linear
- Symmetric flow

Local Address:

Schematics

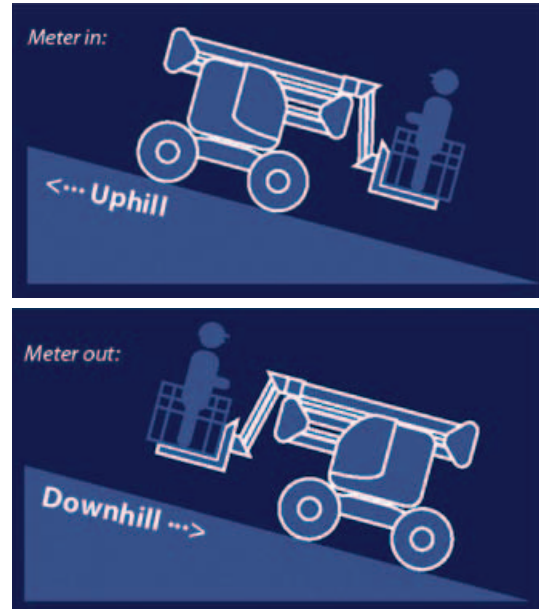
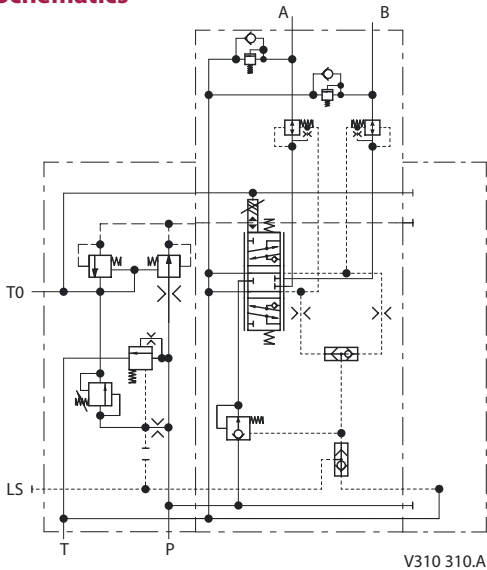

Application Awareness

- With the Meter-In Meter-Out module stability is determined by ensuring that oil flow into the system is always lower than oil flow out of the system. This is achieved by means of different spring settings in the Meter-In Meter-Out compensators. As an example this means that a motor will run faster in Meter-Out mode than in Meter-In mode.
- Due to the Meter-out compensators a backpressure valve is needed to avoid cavitations when running in meter-out situations. High flow out of the valve (>65 l/min) could result in insufficient suction into the low pressure chamber and lead to cavitations. The back pressure setting would be application dependent but typical values are between 5-10 bar. Increased back pressure setting ensures better protection against cavitations but also decrease energy efficiencies. The hydraulic system would be leaking in neutral when external forces acts on the working ports. To avoid unwanted movements of the applied motors, therefore external brakes are needed.
- Dependent on the application type smooth movement could be requested. PVE's in combination with a controller and joystick could be useful to add ramps on the spool and delay on the motor brakes so it doesn't hit the brakes too hard when returning to neutral.

Technical Specifications

Max. pressure	Port P continuous, Port A/B	350 bar [5076 psi]
	Port T static/dynamic	25/40 bar [362/580 psi]
Oil flow, rated	Port A/B and P	130 l/min [34 gal/min]
	Port A/B max. recommended	65 l/min [17 gal/min]
Spool travel		±7 mm [±0.28 in]
Max. internal leakage A/B→T at 100 bar [1450 psi] and 21 mm²/s		1 l/min [61 in ³ /min]
Max. internal leakage A/B→T at 200 bar [2900 psi] and 21 mm²/s		1.5 l/min [92 in ³ /min]
Oil temperature (inlet)	Recommended	30 → 60°C [86 → 140°F]
	Minimum	-30 °C [-22 °F]
	Maximum	90 °C [194 °F]
Ambient temperature		-30 → 60 °C [-22 → 140 °F]
Oil viscosity	Operating range	12 - 75 mm ² /s [65 - 347 SUS]
	Minimum	4 mm ² /s [39 SUS]
	Maximum	460 mm ² /s [2128 SUS]
Filtration, max. contamination (ISO 4406)		18/16/13